



Alberton Wind Farm Feasibility Study

Synergy Wind

RO022600_02 | Revision 2

6th October 2015



Alberton Wind Farm Feasibility Study

Project no: RO022600
 Document title: Alberton Wind Farm Feasibility Report
 Document No.: RO022600_02
 Revision: Revision 2
 Date: 6th October 2015
 Client name: Synergy Wind
 Project manager: Hitesh Bavarva
 Author: Lina Khalil and William Huynh
 File name: Alberton Wind Farm Feasibility_Final_Rev 2_05102015 (KF 6 Oct)

Jacobs Group (Australia) Pty Limited
 ABN 37 001 024 095
 Floor 11, 452 Flinders Street
 Melbourne VIC 3000
 PO Box 312, Flinders Lane
 Melbourne VIC 8009 Australia
 T +61 3 8668 3000
 F +61 3 8668 3001
www.jacobs.com

© Copyright 2015 Jacobs Group (Australia) Pty Limited. The concepts and information contained in this document are the property of Jacobs. Use or copying of this document in whole or in part without the written permission of Jacobs constitutes an infringement of copyright.

Limitation: This report has been prepared on behalf of, and for the exclusive use of Jacobs' Client, and is subject to, and issued in accordance with, the provisions of the contract between Jacobs and the Client. Jacobs accepts no liability or responsibility whatsoever for, or in respect of, any use of, or reliance upon, this report by any third party.

Document history and status

Revision	Date	Description	By	Reviewed	Approved
Rev 1	20/08/15	Draft report for client review	Lina Khalil	Keith Frearson, Hitesh Bavarva	Hitesh Bavarva
Rev 2	06/10/15	Final report	Lina Khalil	Keith Frearson	Keith Frearson

Contents

Executive Summary	1
1. Abbreviations	4
2. Introduction	5
3. Methodology	6
4. South Gippsland Network	7
4.1 Network Configuration.....	7
4.2 66kV sub transmission Lines.....	7
4.3 Zone Substations Loading.....	9
4.4 Other Wind Farms in Region.....	9
5. Thermal Loading Assessment	10
5.1 Peak Load.....	10
5.2 Minimum Load.....	10
6. Maximum Allowable Generation – Existing Network	11
6.1 Generation Under Normal Operating Conditions.....	11
6.2 Generation Under Outage Conditions.....	12
7. Network Augmentations/Costings	13
7.1 Option1: Upgrade existing “YRM - MWTS” 66kV Line.....	13
7.2 Option2: Build a second “YRM - MWTS” 66kV Line.....	14
7.3 Option3: Build a radial 132kV line from Alberton wind farm to MWTS.....	14
8. Additional Considerations	16
9. Conclusion	17
10. References	19

Executive Summary

Synergy Wind Pty Ltd (Synergy Wind) engaged Jacobs to conduct a feasibility study for the network connection of Alberton Wind Farm. The wind farm is estimated to be between 90MW to 130MW in size and located in Alberton (South Gippsland region of Victoria).

Synergy Wind has nominated three 66kV connection points. These are all on the Morwell Terminal Station – Foster (MWTS-FTR) 66kV line. For the purpose of this assessment, Jacobs has assumed connecting the Alberton wind farm at Yarram (YRM) (located approximately midway between MWTS66kV and FTR). Yarram has been selected as a connection point as this is the point that connects the high rated section of the line “YRM – FTR” (103 MVA) and the lower rated section “YRM – MWTS” (63MVA). Any other point of connection on the “YRM – FTR” section would result in comparable results to this assessment. While a connection point on the lower rated section “YRM – MWTS” will introduce additional thermal loading constraints.

The existing Toora wind farm with maximum capacity of 21MW (which also connects onto the MWTS-FTR line) along with the Bald Hills and Wonthaggi wind farms have also been considered in the study. Assessment was based on all wind farms operating at their full capacity.

Jacobs conducted the following to determine the technical and economic viability of the wind farm connection:

- Impact on existing network (i.e. thermal loading constraints of 66kV lines)
- Possible network augmentations to allow full Alberton wind farm generation; and
- Indicative costings of feasible augmentations

Key findings

1. With the existing network and under normal operating conditions, the maximum allowable Alberton wind farm generation ranges from 87MVA (under minimum network loading) to 100MVA (under peak network loading).
2. The two main limiting constraints on the 66kV network are the two low capacity return paths from the 66kV network to MWTS:
 - “YRM – MWTS” line; and
 - “Leongatha (LGA) – MWTS” (Line No.2)
3. Under certain outage conditions on 66kV network, a run back scheme would be required to avoid thermal overloading.
4. A number of feasible augmentation options are proposed to allow additional Alberton wind farm generation export.
5. Table 1 below summarizes the range of wind farm outputs, network augmentations and costings associated - with the following key points:
 - Options 1 and 2 could possibly have close costs but option 2 supports a higher generation
 - Option 2 has a cost advantage of about \$13M over option 3
 - However, Option 3 provides a number of advantages compared to options 1 and 2 as follows:
 - Supports higher generation (200MVA)
 - Generation is NOT restricted by current or future constraints on the existing 66kV network.
 - This option could allow further development stages of wind farm. For example, building a second 132kV line would allow 400MVA generation regardless of any 66kV network constraints

Table 1: Alberton wind farm connection options summary

Connection Option	Augmentation Required	Augmentation Cost (A\$) ¹	Maximum WF Generation (under normal operating conditions)	Run Back Scheme Required?	Comments
Existing network (No augmentations)	Not required	Nil	87MVA (under minimum network loading) to 100MVA (under peak network loading)	YES – under certain outage conditions on 66kV network	Control scheme required to modulate wind farm output based on network loading - Possible option is to modulate wind farm output based on “YRM – MWTS” line loading
Option 1	Upgrade existing “YRM - MWTS” 66kV Line	\$10.1M – \$18M	132MVA	YES – under certain outage conditions on 66kV network	Cost range is subject to detailed field survey
Option 2	Build a second “YRM - MWTS” 66kV Line	\$25M	157MVA	YES – under certain outage conditions on 66kV network	-
Option 3	Build a radial 132kV line from Alberton wind farm to MWTS	\$38.25M	200MVA	No N-1 capability provided - assume 100% loss in output for loss of 132kV line	This option allows further development stages of wind farm - Building a second 132kV line would allow 400MVA generation regardless of any 66kV network constraints

¹ Indicative costing (±30%) – also excludes wind farm substation and associated protection costing

Additional Considerations

The following items are considered outside the scope of this assessment. It is recommended that Synergy Wind seeks advice on the following items from AusNet:

- Frequency of outage conditions in the South Gippsland region 66kV network.
- In particular, recent outage statistics related to “YRM – MWTS” line section which is well-known for its poor reliability.
- Any proposed augmentations in the South Gippsland region to alleviate the network constraints identified in this report.
- Feasibility and cost of easements when considering augmentation options 2 and 3.
- Availability of physical space at MWTS for additional equipments (transformer, switchgear and associated equipments) when considering options 2 and 3.
- For all connection options, cost of communications link back to AusNet.

Important note about your report

The sole purpose of this report and the associated services performed by Jacobs is to conduct a feasibility study for the network connection of Alberton Wind Farm in accordance with the scope of services set out in the contract between Jacobs and the Client. That scope of services, as described in this report, was developed with the Client.

In preparing this report, Jacobs has relied upon, and presumed accurate, any information (or confirmation of the absence thereof) provided by the Client and/or from other sources. Except as otherwise stated in the report, Jacobs has not attempted to verify the accuracy or completeness of any such information. If the information is subsequently determined to be false, inaccurate or incomplete then it is possible that our observations and conclusions as expressed in this report may change.

Jacobs derived the data in this report from information sourced from the Client (if any) and/or available in the public domain at the time or times outlined in this report. The passage of time, manifestation of latent conditions or impacts of future events may require further examination of the project and subsequent data analysis, and re-evaluation of the data, findings, observations and conclusions expressed in this report. Jacobs has prepared this report in accordance with the usual care and thoroughness of the consulting profession, for the sole purpose described above and by reference to applicable standards, guidelines, procedures and practices at the date of issue of this report. For the reasons outlined above, however, no other warranty or guarantee, whether expressed or implied, is made as to the data, observations and findings expressed in this report, to the extent permitted by law.

This report should be read in full and no excerpts are to be taken as representative of the findings. No responsibility is accepted by Jacobs for use of any part of this report in any other context. Project specific variables include but not limited to the completeness and accuracy of supplied data.

This report has been prepared on behalf of, and for the exclusive use of, Jacobs's Client, and is subject to, and issued in accordance with, the provisions of the contract between Jacobs and the Client. Jacobs accepts no liability or responsibility whatsoever for, or in respect of, any use of, or reliance upon, this report by any third party.

1. Abbreviations

BHWF	Bald Hill Wind Farm
FTR	Foster
LGA	Leongatha
PHI	Phillip Island
POC	Point of Connection
PSS/E	Power System Simulator for Engineering
SLD	Single Line Diagram
TF	Transformer
TWF	Toora Wind Farm
WGI	Wonthaggi
WWF	Wonthaggi Wind Farm
YRM	Yarram

2. Introduction

Synergy Wind Pty Ltd (Synergy Wind) engaged Jacobs to conduct a feasibility study for the network connection of Alberton Wind Farm. The wind farm is estimated to be between 90MW to 130MW in size and located in Alberton (South Gippsland region of Victoria).

Synergy Wind has nominated three 66kV connection points. These are all on the Morwell Terminal Station – Foster (MWTS-FTR) 66kV line. For the purpose of this assessment, Jacobs has assumed connecting the Alberton wind farm at Yarram (YRM) (located approximately midway between MWTS66kV and FTR). Yarram has been selected as a connection point as this is the point that connects the high rated section of the line “YRM – FTR” (103 MVA) and the lower rated section “YRM – MWTS” (63MVA). Any other point of connection on the “YRM – FTR” section would result in comparable results to this assessment. While a connection point on the lower rated section “YRM – MWTS” will introduce additional thermal loading constraints.

The existing Toora wind farm with maximum capacity of 21MW (which also connects onto the MWTS-FTR line) along with the Bald Hills and Wonthaggi wind farms have also been considered in the study. Assessment was based on all wind farms operating at their full capacity.

Jacobs conducted the following to determine the technical and economic viability of the wind farm connection:

- Impact on existing network (i.e. thermal loading constraints of 66kV lines)
- Possible network augmentations to allow full Alberton wind farm generation; and
- Indicative costings of feasible augmentations

3. Methodology

As per the scope of work in the proposal, the following items were carried out:

1. Procure network model load flows from AusNet Services (PSS/e models in version 33 were provided)
 - a. Reviewed existing network configuration and line ratings;
 - b. Connected the Alberton wind farm;
 - c. Prepared a peak and minimum load case based on zone substation loading provided by AusNet Services [1].
2. Examine thermal loading constraints on the South Gippsland 66kV sub transmission network.
 - a. Load flow studies were carried out for the peak and minimum load cases. Assessment was based on all wind farms in South Gippsland region in service and operating at full capacity. This includes Toora wind farm (TWF), Wonthaggi wind farm (WWF) and Bald Hills wind farm (BHWF).
 - b. Line thermal loadings were compared against actual line ratings as provided by AusNet Services [2], [3].
3. Based on thermal loading assessment, the maximum Alberton wind farm that can be managed without further network augmentations has been determined.
4. Feasible network augmentation options that would allow full Alberton wind farm generation were determined. Feasibility has been determined using load flows for thermal loading requirements.
5. An indicative cost ($\pm 30\%$) for the feasible augmentations that would allow full generation of Alberton wind farm has been provided.

4. South Gippsland Network

AusNet Services has provided a PSS/e model (in V33) representing the South Gippsland 66kV sub transmission network originating from the MWTS. The following sections describe the network technical data based on information provided by AusNet Services [1], [2], [3].

4.1 Network Configuration

The existing South Gippsland 66kV network in which the connection point for the Alberton wind farm is proposed is shown in Figure 1 below. The network supplies four 66/22kV zone substations; Wonthaggi (WGI), Phillip Island (PHI), Leongatha (LGA) and Foster (FTR).

Synergy Wind has already identified the Morwell West Terminal Station (MWTS) to Foster (FTR) 66kV line that runs through the Alberton region as a potential point of connection. Toora wind farm also connects onto the MWTS - FTR 66kV line.

For the purpose of this study, Jacobs has assumed Alberton wind farm to be connected at Yarram (located approximately at 57km from MWTS 66kV and 44km from FTR) as shown in Figure 1.

Figure 1: 66kV South Gippsland Network (With Alberton wind farm proposed connection)

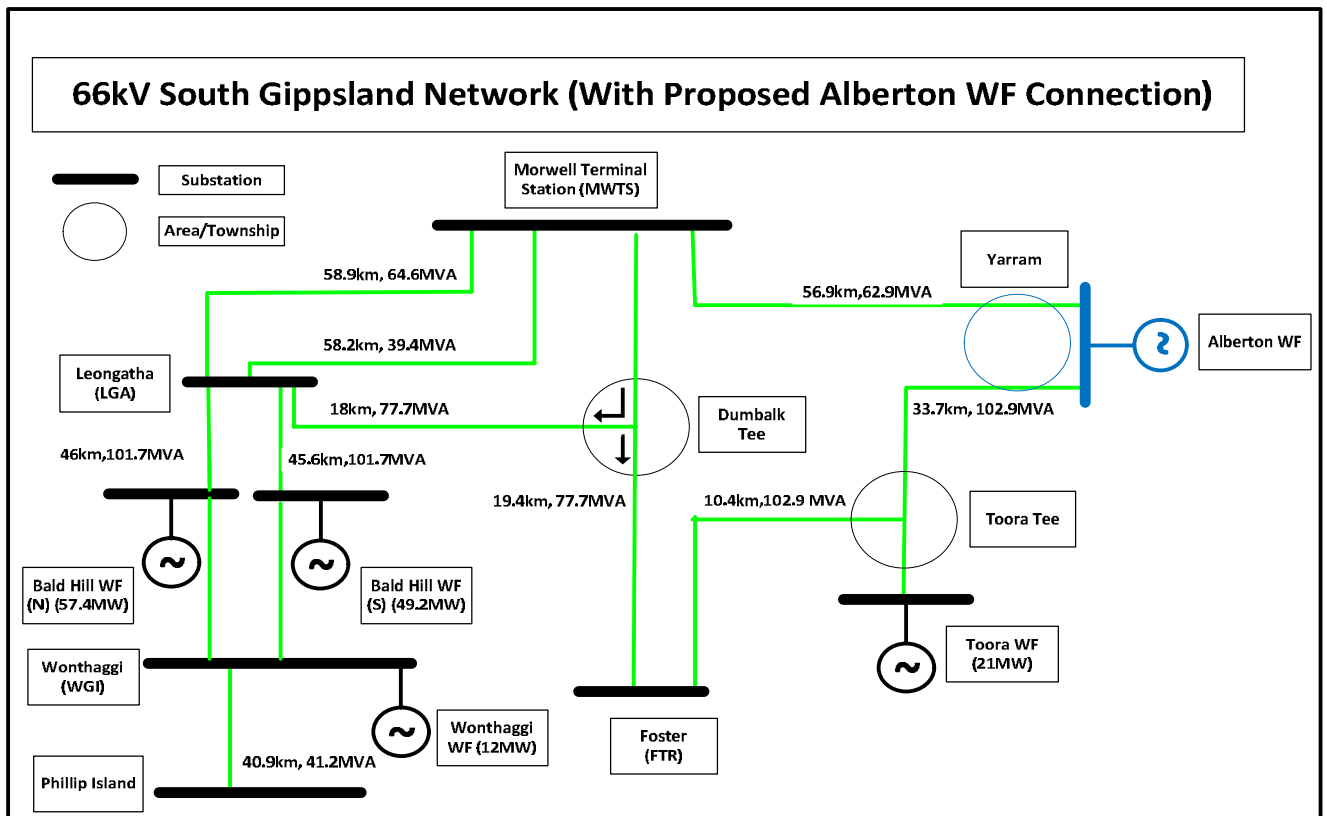

4.2 66kV sub transmission Lines

The following Table 2 lists the existing 66kV sub transmission lines in the South Gippsland transmission network. Line ratings and lengths have been based on circuit data sheets provided by AusNet Services [2], [3]. These lines have been monitored throughout the assessment. The summer line rating has been used as the basis for assessing thermal overloading issues.

It is worth noting that the “Yarram (YRM) – MWTS” line has a significantly lower rating compared to the “YRM – FTR” line with thermal ratings of 62.9MVA and 102.69MVA respectively (Lines highlighted below in orange). As discussed earlier, for the purpose of this assessment, the Alberton wind farm has been assumed to be connected at Yarram. Any point of connection on the “YRM – FTR” 66kV line would result in comparable results to this assessment. While connecting Alberton wind farm to a point on the “YRM – MWTS” 66kV line may introduce additional thermal loading constraints due to line’s low rating.

In addition to the “YRM – MWTS” line low rating, this line section is well –known for its poor reliability. The Toora wind farm was advised that the “YRM – MWTS” line section had an average outage rate of one unplanned outage per week over the previous five years. It would be beneficial for Synergy Wind to seek advice from AusNet on recent outage statistics related to this line section.

The other line of interest is the “LGA – MWTS (Line No.2)” with a low rating compared to the parallel line “LGA – MWTS (Line No.3)” with thermal ratings of 39.4MVA and 64.6MVA respectively (highlighted below in green). This line could potentially become constrained with the addition of Alberton wind farm under specific loading conditions. These constraints will be discussed in detail in section 5 of this report.

Table 2: South Gippsland sub transmission lines

From Bus ¹	To Bus ¹	Length (km)	Summer Line Rating (MVA)
LGA	LSSS1	18.9	101.74
WGI	LSSS1	22.56	32.01
LGA	LSSS/TEE	16.86	101.74
WGI	LSSS/TEE	19.41	101
LSSS2	LSSS/TEE	2.45	101.74
LSSS1	BHWFS66	26.73	100.7
LSSS2	BHWFN66	26.73	100.7
YRM_ALBRT WF ²	MWTS/B2	56.9	62.9
YRM_ALBRT WF ²	TWF/TEE	33.7	102.9
FTR	TWF/TEE	10.38	102.9
MWTS/B1	DUMBALK TEE	43.1	77.73
LGA	DUMBALK TEE	18	77.73
FTR	DUMBALK TEE	19.47	77.73
MWTS/B3	LGA (Line No.2)	58.2	39.44
MWTS/B2	LGA (Line No.3)	58.86	64.59
WGI	PHI	40.9	41.15

1 "From bus" and "To bus" names are as per the PSS/e model provided

2 Point of connection of Alberton WF at Yarram (connection point added to PSS/e model)

4.3 Zone Substations Loading

To assess the technical viability of the Alberton wind farm connection, load flow studies have been carried out for peak and minimum loading conditions.

The current peak and minimum loadings at each zone substation in the South Gippsland network has been based on information provided by AusNet Services [1]. Table 3 below represents the network loading used for the modelling purposes for this study.

The load growth data in the South Gippsland area [1] shows less than 5% growth over a nine year outlook period (2016 - 2024). For the purpose of this study, Jacobs considered this load growth of negligible impact on the study results.

Table 3: Zone substations peak and minimum loadings

Zone Substation	Peak Loading		Minimum Loading	
	MW	MVA _r	MW	MVA _r
LGA	38.4	11.7	14	5
WGI	34.8	9	10	2
PHI	19.4	2	4	1
FTR	19.3	6.8	6	2
Total	111.9	29.5	34.8	10

4.4 Other Wind Farms in Region

There are currently three wind farms connected to the South Gippsland 66kV network; Bald Hills wind farm (BHWF), Wonthaggi wind farm (WWF) and Toora wind farm (TWF).

The wind farm capacity and location of these three wind farms is provided in Table 4 below.

Table 4: Wind farms connected to South Gippsland 66kV network

Wind Farm	Capacity (MW)	Location
Bald Hills	106.6	On LGA – WGI 66kV line
Wonthaggi	12	On 22kV feeder at WGI
Toora	21	On MWTS-FTR 66kV line

As discussed earlier, Toora wind farm is connected on the same “MWTS-FTR” 66kV line in which Alberton wind farm is proposed to be connected. The impact of all three wind farms is considered in the thermal loading assessment carried out in the following section.

5. Thermal Loading Assessment

This section presents the results of the thermal loading assessment undertaken to assess the impact of Alberton wind farm connection on the South Gippsland 66kV network.

Assessment has been carried out for the peak and minimum load cases with all the wind farms in region operating at full capacity.

In order to compare the Alberton wind farm capacity with the thermal loading of the 66kV network, the wind farm capacity throughout the report is presented in MVA. The MVA generation has been based on Alberton wind farm holding terminal voltage close to 1p.u. With an assumed Alberton wind farm output of 130MW, holding terminal voltage to 1p.u. has resulted in wind farm operating at a power factor of 0.98 for peak load case and 0.97 for light load case.

5.1 Peak Load

With a total peak load of 112MW on the South Gippsland 66kV network and total wind farm generation in the region of approximately 270MW, thermal loading constraints are expected due to excessive generation flow from the 66kV network back to MWTS.

As expected, the assessment has shown that the “YRM – MWTS” 66kV line is overloaded due to the relatively lower rating as detailed in Table 5 below. All other 66kV sub-transmission lines will be within their thermal ratings.

Table 5: Peak load case thermal loading constraints

From Bus	To Bus	Length (km)	Summer Line Rating (MVA)	Loading (MVA)	Loading (as % of summer rating)
YRM_ALBRT WF	MWTS/B2	56.9	62.9	80.5	127

5.2 Minimum Load

With a total minimum loading of 35MW (approximately 30% of the peak loading) on the South Gippsland 66kV network, additional thermal loading constraints would be expected compared to peak load conditions.

The assessment has shown that the “YRM – MWTS” 66kV line is heavily overloaded while the return path from LGA to MWTS through “LGA – MWTS (Line No.2)” 66kV line just exceeds its thermal rating as detailed in Table 6 below. All other 66kV sub-transmission lines will be within their thermal ratings.

Table 6: Minimum load case thermal loading constraints

From Bus	To Bus	Length (km)	Summer Line Rating (MVA)	Loading (MVA)	Loading (as % of summer rating)
YRM_ALBRT WF	MWTS/B2	56.9	62.9	89.69	143
MWTS/B3	LGA (Line No.2)	58.2	39.4	41.07	104

The study results have shown that the two main limiting constraints for the Alberton wind farm is the thermal rating of the “YRM – MWTS” and “LGA – MWTS (Line No.2)” 66kV lines. The following section identifies the maximum allowable Alberton wind farm generation with existing network (i.e. no network augmentations).

6. Maximum Allowable Generation – Existing Network

This section identifies the maximum allowable Alberton wind farm generation with the existing network (i.e. no network augmentations). This assessment has been based on the network thermal loading constraints. The maximum allowable generation is based on steady state network assessment and no dynamic studies have been performed to assess the network stability. The maximum determined capacity in this section may vary due to network stability issues. Detailed stability studies are recommended to confirm the maximum possible generation from the Alberton wind farm once the tentative wind turbine generator is selected for the site.

The maximum generation is determined for normal operating conditions and under certain outage conditions as described below.

The maximum MVA generation has been based on Alberton wind farm holding terminal voltage close to 1p.u.

6.1 Generation Under Normal Operating Conditions

The maximum Alberton wind farm generation under specific loading and normal operating conditions (i.e. no outages) is as shown in Figure 2 below.

The study results show that the maximum allowable Alberton wind farm generation under normal operating conditions ranges from 87MVA (under minimum loading) to 100MVA (under peak loading).

A control scheme would be required if the wind farm output is to be modulated (i.e. 100MVA to 87MVA) based on network loading. One possible option would be to monitor the “YRM – MWTS” line loading and modulate wind farm output accordingly.

Figure 2: Alberton wind farm maximum generation against network loading conditions

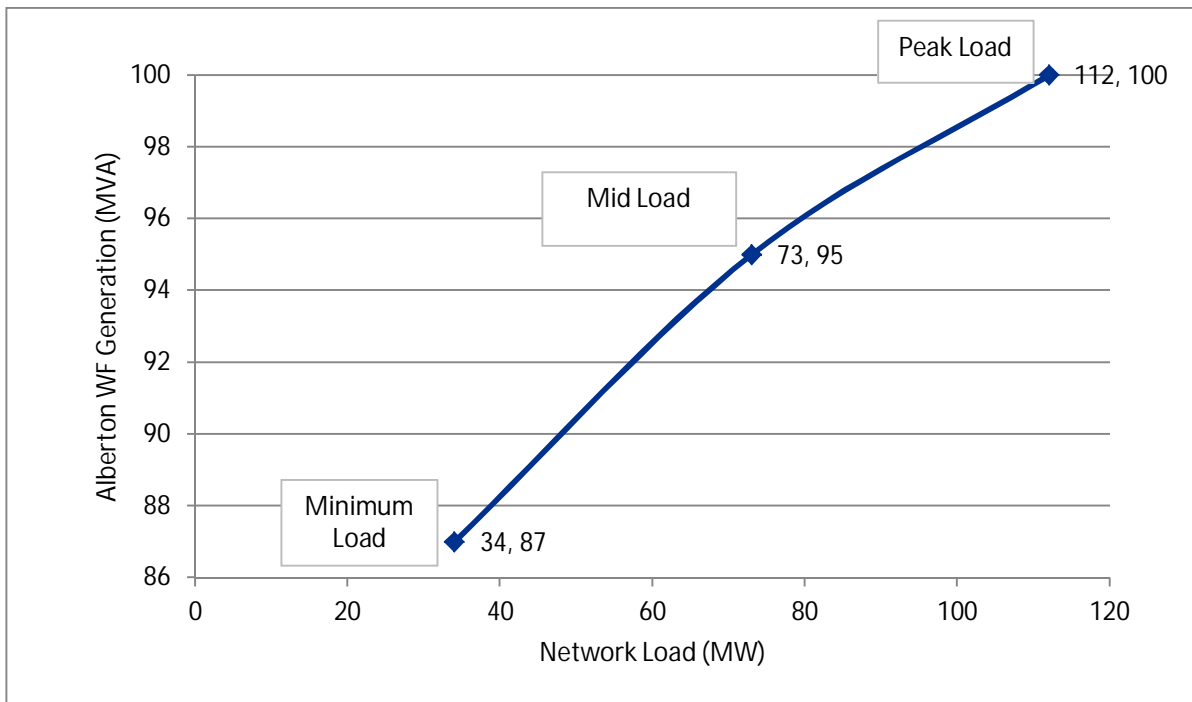

6.2 Generation Under Outage Conditions

The following main outage conditions have been considered under minimum network loading conditions as the minimum network loading has the most restrictive generation from the Alberton wind farm:

- Outage of “LGA – MWTS” (Line No.3)
- Outage of “YRM – MWTS” line
- Outage of “YRM – FTR” line
- Outage of “LGA – MWTS” (Line No.2)

The maximum allowable wind farm output during the considered outage conditions are listed in Table 7 below.

Table 7: Alberton wind farm maximum generation – Under outage conditions

Outage condition	Alberton WF Maximum Generation (MVA)	Main Constraining Line
“LGA – MWTS” (Line No.3)	39	“LGA – MWTS” (Line No.2)
“YRM – MWTS” line	52	“LGA – MWTS” (Line No.2)
“YRM – FTR” line	63	“YRM – MWTS” line
“LGA – MWTS” (Line No.2)	80	“YRM – MWTS” line

As discussed earlier in this report, the two main limiting lines on the 66KV network are the two return paths from the 66kV network to MWTS; “YRM – MWTS” and “LGA – MWTS” (Line No.2).

The outage condition resulting in the lowest Alberton wind farm generation is the outage of “LGA – MWTS” (Line No.3) which overloads the parallel “LGA – MWTS” (Line No.2) line due to the lower thermal rating.

In order to reduce the wind farm output from levels identified under normal operating conditions (shown in Figure 2) to reduced output under outage conditions (listed in Table 7), a run back scheme would be required. The actual wind farm output for the run back scheme will require detailed studies to determine exact levels under different loading and outage conditions.

7. Network Augmentations/Costings

Assessment has shown that with the existing network and under normal operating conditions, the maximum allowable Alberton wind farm generation ranges from 87MVA (under minimum loading) to 100MVA (under peak loading).

This section describes the feasible network augmentations that could be implemented to allow higher generation export.

This assessment has been based on the following operating conditions:

- Minimum network loading conditions
- MVA generation has been based on Alberton wind farm holding terminal voltage close to 1p.u

Three possible augmentation options have been identified.

The indicative costings ($\pm 30\%$) of these augmentations are also presented and are based on the following assumptions:

- Costs represent indicative costings ($\pm 30\%$)
- Costs exclude wind farm substation (step-up transformers, switchgear and associated protection)
- Costs exclude any possible required power lines from the wind farm site to the selected connection point
- Costs exclude land acquisition, easements and site development
- Costs exclude any control scheme required to manage any constraints
- Costs exclude establishing communication links back to AusNet
- Jacobs has determined the cost for each option based on their past experience and indicative prices from some of the suppliers (where available)
- The cost for each option is at high level and may not be suitable for any tendering or any other similar purposes. These costs are to provide indicative costs for each option such that Synergy Wind can use these figures in their economical modelling as indicative values.

7.1 Option 1: Upgrade existing “YRM - MWTS” 66kV Line

Option 1 involves upgrading the existing Yarram to MWTS 66kV line to a higher rated line. Assuming this line is upgraded to a line with a similar rating to the ‘YRM – FTR’ line (102.9MVA), the maximum allowable Alberton wind farm generation would be 132MVA. The wind farm output beyond this level will overload the LGA-MWTS (Line No.2).

Providing a detailed cost for upgrading the existing 66kV line would require a detailed field survey. With the assumption that existing line upgrade would mainly require re-conductoring work along with insulators replacement (excluding poles replacement), the cost of upgrade would be approximately 40% of the cost of building a new 66kV line.

As per the information provided by AusNet Services ([2], [3]), the existing circuit breaker (CB) rating (at MWTS66kV) is not adequate for the upgraded line rating and will need to be replaced.

The total indicative cost of this option is **\$10.1M** - as detailed in Table 8 below.

Table 8: Option 1 indicative cost breakdown

Item	Unit	Quantity	Unit Cost (A\$K)	Total Cost (A\$K)
Upgrade single circuit 66kV line from YRM to MWTS ¹	No.	1	\$9,000	\$9,000
Replace 66kV CBs + isolators at MWTS	No.	1	\$1,100	\$1,100
Total				\$10,100

¹This includes conductor cost, stringing and insulators cost

However, we don't believe that this is a reasonable assumption. Subject to field survey, some poles may require replacement to support the new conductor size. This could possibly result in an upgrade cost of approximately 70% of the cost of building a new line. The total indicative cost of this option would be approximately **\$18 M**.

With the cost of upgrading the existing line expected to be close to building a new line, the following option 2 suggests building a second 66kV line parallel to existing line.

7.2 Option 2: Build a second “YRM - MWTS” 66kV Line

This option involves building a second line from Yarram to MWTS in parallel to the existing line. This new line is assumed to be of a similar rating to the ‘YRM – FTR’ line (102.9MVA). This option would allow Alberton wind farm generation of 157MVA with no thermal loading constraints.

However, a run back scheme would still be required under specific outage conditions on the 66kV network. As discussed earlier in this report, an outage condition of “LGA – MWTS” (Line No.3) would constrain the Alberton wind farm output significantly. With this augmentation option, the wind farm output would still be constrained to 70MVA under this outage condition.

The total indicative cost of this augmentation option is **\$25M** - Table 9 below shows a breakdown of the costs associated with Option 2.

Table 9: Option 2 indicative cost breakdown

Item	Unit	Quantity	Unit Cost (A\$K)	Total Cost (A\$K)
Single circuit 66kV pole line from YRM to MWTS	km	57	\$400	\$22,800
66kV CBs + isolators at YRM	No.	1	\$1,100	\$1,100
66kV CBs + isolators at MWTS	No.	1	\$1,100	\$1,100
Total				\$25,000

7.3 Option 3: Build a radial 132kV line from Alberton wind farm to MWTS

Assessment has shown that the Alberton wind farm connection on the 66kV network is limited by thermal loading constraints across the 66kV network under certain loading and/or outage conditions. This leads to option 3, in which a dedicated 132kV radial line is proposed to connect the wind farm directly into MWTS. This allows 200MVA generation and is not impacted by current or future constraints on the 66kV network.

This option involves building a new 132kV radial line from Alberton wind farm to MWTS. This would also require a 132/66kV substation (step-down transformer and associated protection) for a connection at MWTS 66kV bus or a 132/220kV substation (step-up transformer and associated protection) for a connection at MWTS 220kV bus.

This solution does not provide N-1 capability (assume 100% loss in output for loss of line). The N-1 design would require the use of a double circuit and additional transformer at MWTS at a significant extra cost.

The total indicative cost of this option (connection at MWTS 66kV) is **\$38.25 M** - Table 10 below shows a breakdown of the costs associated with Option 3.

Table 10: Option 3 indicative cost breakdown

Item	Unit	Quantity	Unit Cost (A\$K)	Total Cost (A\$K)
Single circuit 132kV pole line from Alberton WF to MWTS	km	57	\$500	\$28,500
132V CBs + isolators at Alberton WF	No.	1	\$1,550	\$1,550
66/132kV transformer (200 MVA)	No.	1	\$2,500	\$2,500
66/132kV substation establishment (excluding building)	No.	1	\$1,500	\$1,500
132V CBs + isolators at substation (for transformer and 132kV line at MWTS end)	No.	2	\$1,550	\$3,100
66V CBs + isolators at substation	No.	1	\$1,100	\$1,100
Total				\$38,250

While Option 3 is significantly more expensive than either Option 1 or Option 2, it does provide a number of advantages, as follows:

- Supports higher generation (200MVA)
- Generation is NOT restricted by current or future constraints on the existing 66kV network
- This option could allow further development stages of wind farm. For example, building a second 132kV line would allow 400MVA generation regardless of any 66kV network constraints.

8. Additional Considerations

The following items are considered outside the scope of this assessment. It is recommended that Synergy Wind seeks advice on the following items from AusNet:

- Frequency of outage conditions in the South Gippsland region 66kV network. A number of outage conditions have been assessed in this report and the impact on Alberton wind farm output presented. It would be beneficial to seek advice from AusNet on the frequency of such outages and whether augmentations are planned to reduce frequency of outages.
- Recent outage statistics related to “YRM – MWTS” line section in particular. As discussed in this report, this line section is well-known for its poor reliability. It would be beneficial to seek advice on recent outage statistics compared to previously provided information for other wind farm connections in the region.
- Any proposed augmentations in the South Gippsland region to alleviate the network constraints identified in this report. The 2014 annual planning report does not include any planned upgrades to the South Gippsland 66kV network. In addition, the flat load forecast does not indicate that there would be any upgrades in the region. Synergy Wind may confirm this with AusNet.
- Feasibility and cost of easements when considering augmentation options 2 and 3. Options 2 and 3 involve constructing new lines which will require easement arrangements with AusNet. In the case that easement for a new line is not feasible, a possible option would be to overbuild the existing “YRM – MWTS” line utilizing the existing easement. The feasibility and cost of this option would need to be weighed up against the proposed options 2 and 3.
- Availability of physical space at MWTS for additional equipments (transformer, switchgear and associated equipments) when considering options 2 and 3.
- For all connection options, cost of communications link back to AusNet.

9. Conclusion

The following are the key findings of assessment:

1. With the existing network and under normal operating conditions, the maximum allowable Alberton wind farm generation ranges from 87MVA (under minimum network loading) to 100MVA (under peak network loading).
2. The two main limiting constraints on the 66kV network are the two low capacity return paths from the 66kV network to MWTS:
 - “YRM – MWTS” line; and
 - “Leongatha (LGA) – MWTS” (Line No.2)
3. Under certain outage conditions on 66kV network, a run back scheme would be required.
4. A number of feasible augmentation options are proposed to allow additional Alberton wind farm generation export.
5. Table 1 below summarizes the range of wind farm outputs, network augmentations and costings associated - with the following key points:
 - Options 1 and 2 could possibly have close costs but option 2 supports a higher generation
 - Option 2 has a cost advantage of about \$13M over option 3
 - However, Option 3 provides a number of advantages compared to options 1 and 2 as follows:
 - Supports higher generation (200MVA)
 - Generation is NOT restricted by current or future constraints on the existing 66kV network
 - This option could allow further development stages of wind farm. For example, building a second 132kV line would allow 400MVA generation regardless of any 66kV network constraints

Table 11: Alberton wind farm connection options summary

Connection Option	Augmentation Required	Augmentation Cost (A\$) ¹	Maximum WF Generation (under normal operating conditions)	Run Back Scheme Required?	Comments
Existing network (No augmentations)	Not required	Nil	87MVA (under minimum network loading) to 100MVA (under peak network loading)	YES – under certain outage conditions on 66kV network	Control scheme required to modulate wind farm output based on network loading - Possible option is to modulate wind farm output based on “YRM – MWTS” line loading
Option 1	Upgrade existing “YRM - MWTS” 66kV Line	\$10.1M – \$18M	132MVA	YES – under certain outage conditions on 66kV network	Cost range is subject to detailed field survey

Connection Option	Augmentation Required	Augmentation Cost (A\$) ¹	Maximum WF Generation (under normal operating conditions)	Run Back Scheme Required?	Comments
Option 2	Build a second "YRM - MWTS" 66kV Line	\$25M	157MVA	YES – under certain outage conditions on 66kV network	-
Option 3	Build a radial 132kV line from Alberton wind farm to MWTS	\$38.25M	200MVA	No N-1 capability provided - assume 100% loss in output for loss of 132kV line	This option allows further development stages of wind farm - Building a second 132kV line would allow 400MVA generation regardless of any 66kV network constraints

¹ Indicative costing (±30%) – also excludes wind farm substation and associated protection costing

10. References

- [1] South Gippsland network technical data (SynergyWind_SGLData_03082015.pdf)
- [2] AusNet Services Circuit Data Sheet (CDS-WGI-LSSS-PHI-2015.pdf)
- [3] AusNet Services Circuit Data Sheet (CDS-MWTS-LGA-FTR-2015.pdf)